

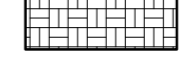

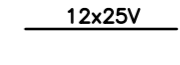



LEGENDA

-  OPBREKEN BETONSTRAATSTENEN KF
-  OPBREKEN OPSLUITBAND 120X250MM
-  VERWIJDEN STRAATKOLK
-  OP HOOGTE TE STELLEN PUTRAND
-  TE HANDHAVEN BOOM
-  MAAIEN EN FREZEN GRAS
-  PERCEELSGRENS
-  WERKGRENS

D				
C				
B				
A				
Wpl.	Get.	Acc.	Datum	Omschrijving
Opdrachtgever		gemeente Doetinchem		afdeling Fysieke Ontwikkeling Ingenieursbureau
Project		Woonrij maken Heideslag Koksgoed Fase I		Status DEFINITIEF
Onderdeel		Te verwijderen materialen		Besteknummer 970-4 Bladnummer 1/5 Schaal 1:500 Format A1
Gepland	H.W.	06-09-13	Projectnummer	98970
Gecontroleerd	M.D.	06-09-13	Tekeningnummer	IB3103-012
Accoord	M.D.	06-09-13	<small> Beeldmerk: Oude Tolwegweg 202-204, 7004 KA Doetinchem Postbus: Raadhuisstraat 2, Postbus 9020, 7000 HA Doetinchem Telefoon (0314) 27 72 77 Telefax (0314) 34 34 37 E-mail gemeente@doetinchem.nl </small>	













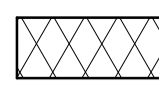
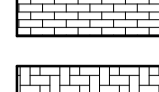
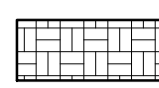
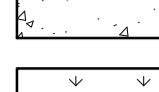
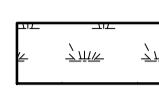
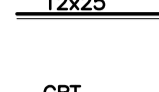

LEGENDA

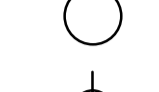
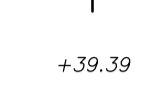
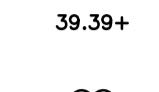
	WATER	WATER	WATERLEIDING VITENS
	GAS LD	GAS LD	GASLEIDING LAGE DRUK LIANDER
	GAS HD	GAS HD	GASLEIDING HOGE DRUK LIANDER
	LS	LS	LAAGSPANNING LIANDER
	MS	MS	MIDDENSPPANNING LIANDER
	KPN	KPN	DATA KPN
	DATA	DATA	DATA LIANDER
	CAI	CAI	DATA UPC

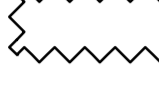
D					
C					
B					
A					
Wf:	Get.	Acc.	Datum	Omschrijving	
Opdrachtgever					
gemeente Doetinchem					afdeling Fysieke Ontwikkeling Ingenieursbureau
Project					Status
Woonrijp maken Heideslag Koksgoed Fase I					DEFINITIEF
					Bladzaknummer
					Bladnummer
					Schaal
					Formaat
Onderdeel					
Bestaande kabels en leidingen					
Getekend	H.W.	06-09-13	Projectnummer	98970	
Gecontroleerd	M.D.	06-09-13	Tekeningnummer	IB3103-017	
Accoord	M.D.	06-09-13	<small> Assistentie: Oude, Teltingweg 202-204, 7004 KA Doetinchem Postbus: Raaijmakerslaan 2, Postbus 9020, 7000 HA Doetinchem Telefoon: (0314) 27 72 77 Telefax: (0314) 34 34 37 E-mail: gemeente@doetinchem.nl </small>		

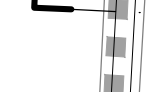

LEGENDA

-  AAN TE BRENGEN ASFALTVERRIJDING
-  SBS, 5% KLEUR MINGAAN HALFTIENVERBAND
-  SBS, 5% KLEUR MINGAAN ELLEBOOGVERBAND
-  SBS, 5% KLEUR GRUIS BLOKVERBAND
-  STABILIZER, KLEUR GRUIS LAAGDIKTE 50MM
-  GRAS T.P.V. WADI
-  GRAS T.P.V. BERNEN
-  12x25 OPSLUITBAND 120x250MM GRUIS
-  GBT GRASBETON TEZEL 400x800x120MM HANDBREKEND LANGS ASFALT
-  STRAATKOLK, AFMETINGEN KOLKHOOP 300x400MM
-  OP HOODTE TE STELLEN PUTRAND
-  LICHTMAST DOOR DERDE TE PLAATSEN
-  +39.39 BESTAANDE TERREINHOOGTE'S
-  39.39+ TE MAKEN TERREINHOOGTE'S
-  NIEUW TE PLAANTEN BOMEN (DOOR DERDEN)
-  TE HANDBREKEND BOOM
-  GEMENGDE HEESTERHAG
-  WERKGRENS

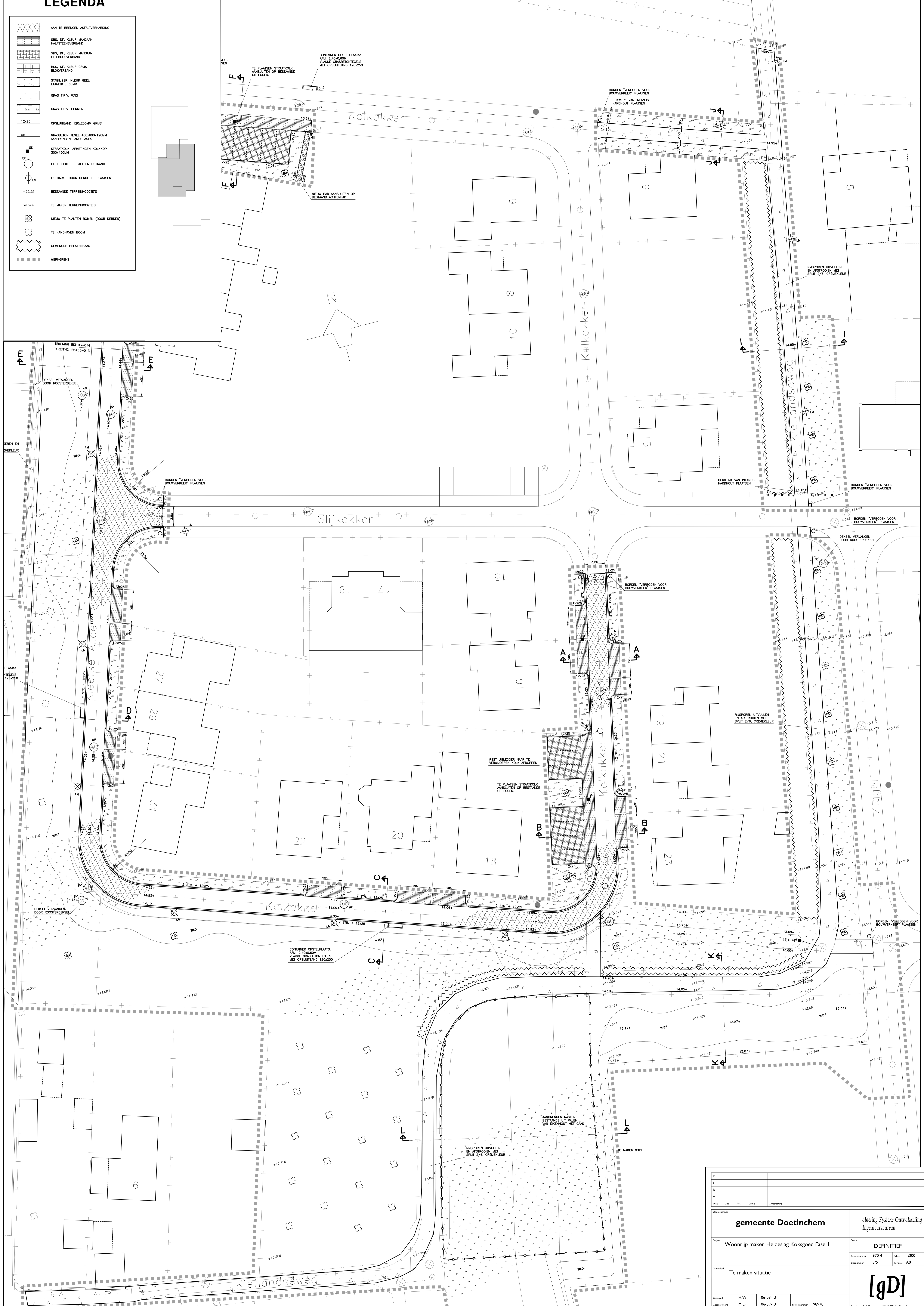

D					
C					
B					
A					
Info	Gen	Act	Datum	Oorsprong	
Opdrachtgever			gemeente Doetinchem		
Project			Woonrijp maken Heideslag Koksgoed Fase I		
Opsteller			Te maken situatie		
afdeling Fysieke Ontwikkeling			Ingenieursbureau		
Status			DEFINITIEF		
Bouwnummer		970-4		Schaal	
Bouwwaard		3/5		Formaat	
				A0	
[gD]					
Gepland	H.V.	06-09-13	Projectnummer	9870	
Gepland	M.D.	06-09-13	Tekeningnummer	1B3103-014	
Aanvullend	M.D.	06-09-13	Assistentie: Gabe Tiedema, 020-261 589 00, 06-43 23 23 23 Verantwoordelijk: Gabe Tiedema, 020-261 589 00, 06-43 23 23 23		

LEGENDA

	aan te brengen ASFALTYVERHARDING
	SBS, OF, KLEUR MANGAAN HALFSTRENGENING
	SBS, OF, KLEUR MANGAAN ELLEBOOGVERBAND
	SBS, KF, KLEUR GRUIS BLOKVERBAND
	STABILIZER, KLEUR, GRUIS LAAGDikte 50MM
	GRAS T.P.V. WADI
	GRAS T.P.V. BERMEN
	OPSLUITBAND 120x25MM GRUIS
	GRASBETON TEZEL 400x800x120MM HAFSTRENGEN LANGS ASFALT
	STRAATKOLK, AFMETINGEN KOLKHOOP 300x400MM
	OP HOOGTE TE STELLEN PUTRAND
	LIJCHTMAAT DOOR DERDE TE PLAATSEN BESTAANDE TERREINHOOGTE'S
	TE MAKEN TERREINHOOGTE'S
	NIJEUW TE PLANTEN BOMEN (DOOR DERDEN)
	TE HANDEHAVEN BOOM
	GEWENSGE HEESTERHAG
	WERKGRENS

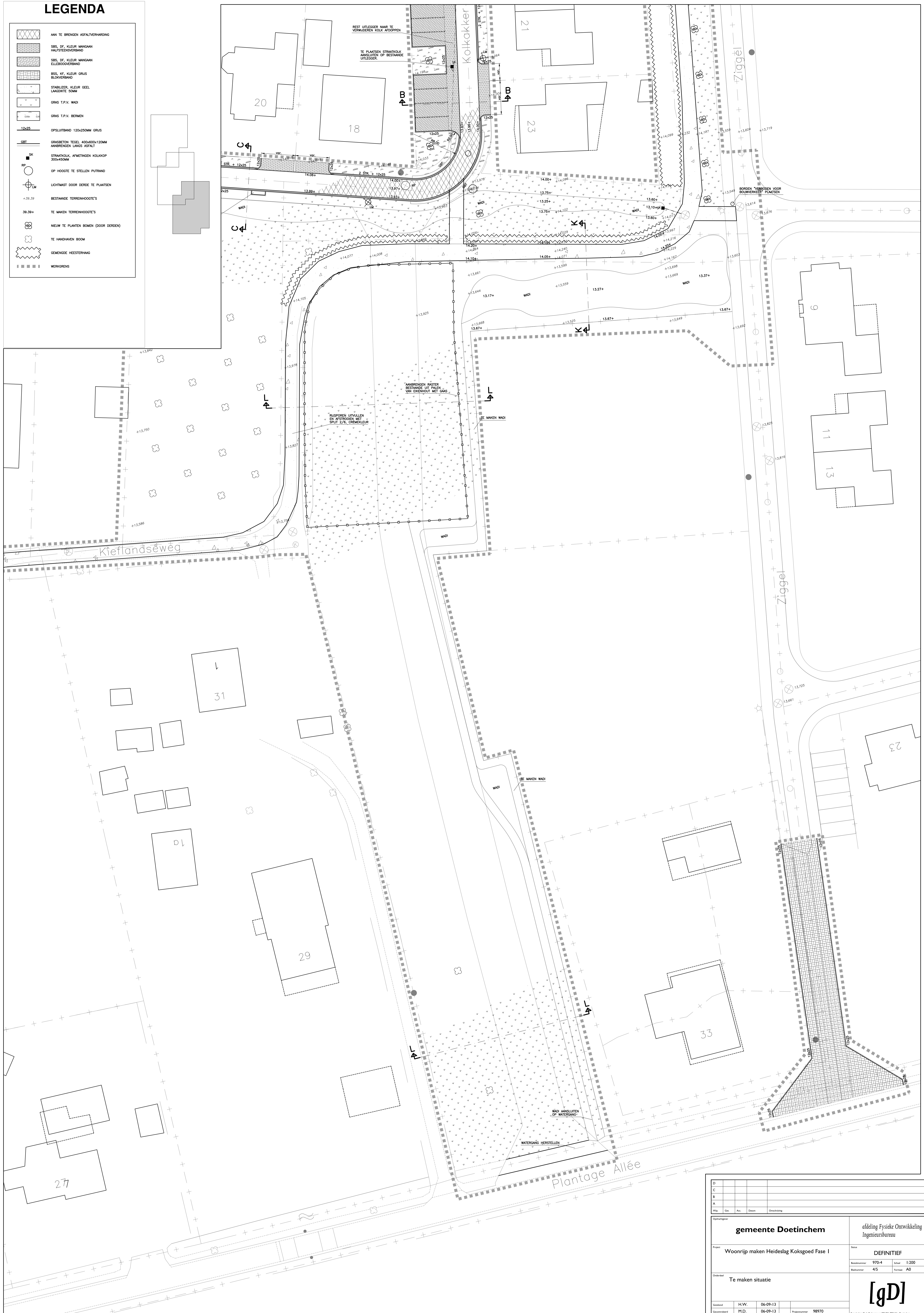

D					
C					
B					
A					
Wfs	Gen	Adv	Daar	Ondertek	
Opdrachtgever					
gemeente Doetinchem			afdeling Fysieke Ontwikkeling Ingenieursbureau		
Project					
Woonrijp maken Heideslag Koksgoed Fase I			Staat		
			DEFINITIEF		
			Bouwnummer		
			970-4		
			Schaal		
			1:200		
			Bouwnummer		
			415		
			Formaat		
			A0		
Onderwerp					
Te maken situatie					
[gD]					
Ontwerper	H.V.	06-09-13	Projectnummer	98970	
Gepland	M.D.	06-09-13	Tekeningnummer	1B3103-015	
Beoordeld	M.D.	06-09-13	Assistentie: Oude Tekening 1B3103-015, 1B3103-016, 1B3103-017, 1B3103-018, 1B3103-019, 1B3103-020, 1B3103-021, 1B3103-022, 1B3103-023, 1B3103-024, 1B3103-025, 1B3103-026, 1B3103-027, 1B3103-028, 1B3103-029, 1B3103-030, 1B3103-031, 1B3103-032, 1B3103-033, 1B3103-034, 1B3103-035, 1B3103-036, 1B3103-037, 1B3103-038, 1B3103-039, 1B3103-040, 1B3103-041, 1B3103-042, 1B3103-043, 1B3103-044, 1B3103-045, 1B3103-046, 1B3103-047, 1B3103-048, 1B3103-049, 1B3103-050, 1B3103-051, 1B3103-052, 1B3103-053, 1B3103-054, 1B3103-055, 1B3103-056, 1B3103-057, 1B3103-058, 1B3103-059, 1B3103-060, 1B3103-061, 1B3103-062, 1B3103-063, 1B3103-064, 1B3103-065, 1B3103-066, 1B3103-067, 1B3103-068, 1B3103-069, 1B3103-070, 1B3103-071, 1B3103-072, 1B3103-073, 1B3103-074, 1B3103-075, 1B3103-076, 1B3103-077, 1B3103-078, 1B3103-079, 1B3103-080, 1B3103-081, 1B3103-082, 1B3103-083, 1B3103-084, 1B3103-085, 1B3103-086, 1B3103-087, 1B3103-088, 1B3103-089, 1B3103-090, 1B3103-091, 1B3103-092, 1B3103-093, 1B3103-094, 1B3103-095, 1B3103-096, 1B3103-097, 1B3103-098, 1B3103-099, 1B3103-100, 1B3103-101, 1B3103-102, 1B3103-103, 1B3103-104, 1B3103-105, 1B3103-106, 1B3103-107, 1B3103-108, 1B3103-109, 1B3103-110, 1B3103-111, 1B3103-112, 1B3103-113, 1B3103-114, 1B3103-115, 1B3103-116, 1B3103-117, 1B3103-118, 1B3103-119, 1B3103-120, 1B3103-121, 1B3103-122, 1B3103-123, 1B3103-124, 1B3103-125, 1B3103-126, 1B3103-127, 1B3103-128, 1B3103-129, 1B3103-130, 1B3103-131, 1B3103-132, 1B3103-133, 1B3103-134, 1B3103-135, 1B3103-136, 1B3103-137, 1B3103-138, 1B3103-139, 1B3103-140, 1B3103-141, 1B3103-142, 1B3103-143, 1B3103-144, 1B3103-145, 1B3103-146, 1B3103-147, 1B3103-148, 1B3103-149, 1B3103-150, 1B3103-151, 1B3103-152, 1B3103-153, 1B3103-154, 1B3103-155, 1B3103-156, 1B3103-157, 1B3103-158, 1B3103-159, 1B3103-160, 1B3103-161, 1B3103-162, 1B3103-163, 1B3103-164, 1B3103-165, 1B3103-166, 1B3103-167, 1B3103-168, 1B3103-169, 1B3103-170, 1B3103-171, 1B3103-172, 1B3103-173, 1B3103-174, 1B3103-175, 1B3103-176, 1B3103-177, 1B3103-178, 1B3103-179, 1B3103-180, 1B3103-181, 1B3103-182, 1B3103-183, 1B3103-184, 1B3103-185, 1B3103-186, 1B3103-187, 1B3103-188, 1B3103-189, 1B3103-190, 1B3103-191, 1B3103-192, 1B3103-193, 1B3103-194, 1B3103-195, 1B3103-196, 1B3103-197, 1B3103-198, 1B3103-199, 1B3103-200, 1B3103-201, 1B3103-202, 1B3103-203, 1B3103-204, 1B3103-205, 1B3103-206, 1B3103-207, 1B3103-208, 1B3103-209, 1B3103-210, 1B3103-211, 1B3103-212, 1B3103-213, 1B3103-214, 1B3103-215, 1B3103-216, 1B3103-217, 1B3103-218, 1B3103-219, 1B3103-220, 1B3103-221, 1B3103-222, 1B3103-223, 1B3103-224, 1B3103-225, 1B3103-226, 1B3103-227, 1B3103-228, 1B3103-229, 1B3103-230, 1B3103-231, 1B3103-232, 1B3103-233, 1B3103-234, 1B3103-235, 1B3103-236, 1B3103-237, 1B3103-238, 1B3103-239, 1B3103-240, 1B3103-241, 1B3103-242, 1B3103-243, 1B3103-244, 1B3103-245, 1B3103-246, 1B3103-247, 1B3103-248, 1B3103-249, 1B3103-250, 1B3103-251, 1B3103-252, 1B3103-253, 1B3103-254, 1B3103-255, 1B3103-256, 1B3103-257, 1B3103-258, 1B3103-259, 1B3103-260, 1B3103-261, 1B3103-262, 1B3103-263, 1B3103-264, 1B3103-265, 1B3103-266, 1B3103-267, 1B3103-268, 1B3103-269, 1B3103-270, 1B3103-271, 1B3103-272, 1B3103-273, 1B3103-274, 1B3103-275, 1B3103-276, 1B3103-277, 1B3103-278, 1B3103-279, 1B3103-280, 1B3103-281, 1B3103-282, 1B3103-283, 1B3103-284, 1B3103-285, 1B3103-		

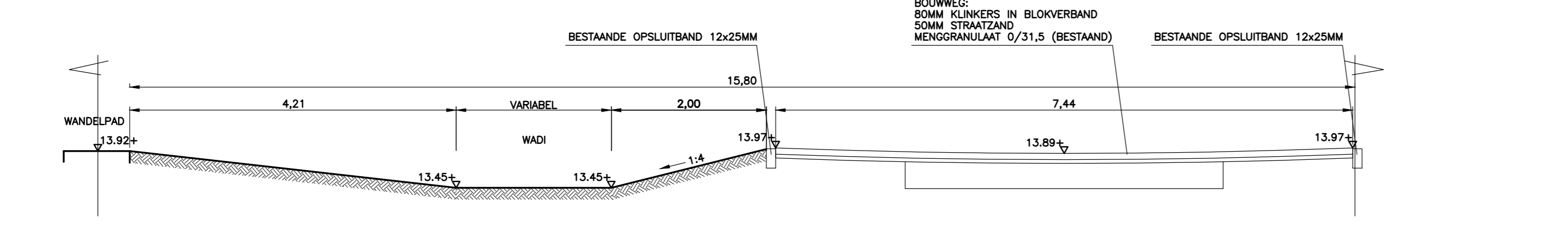
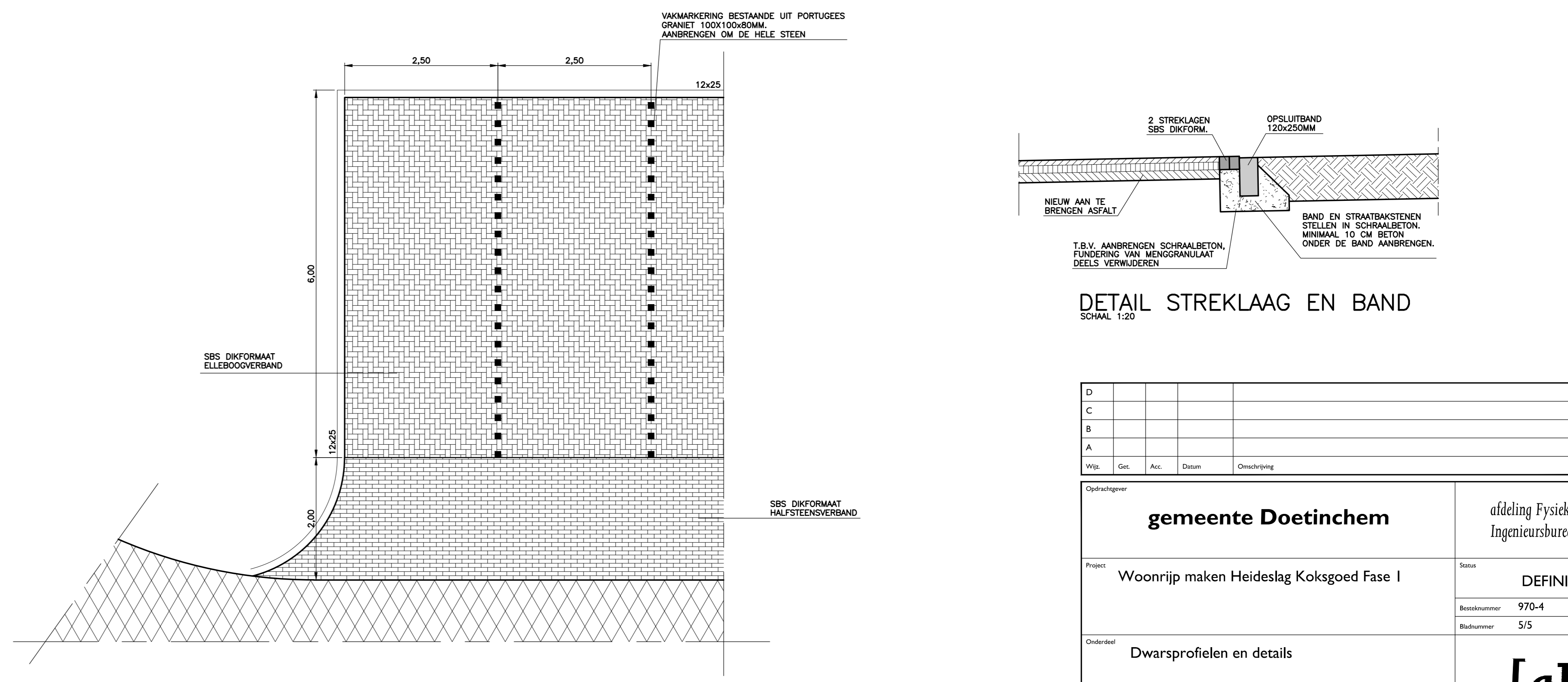
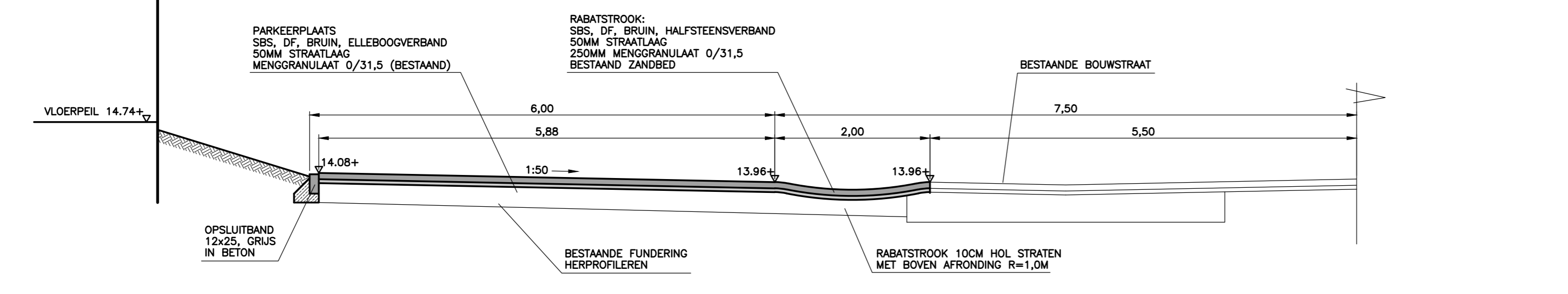
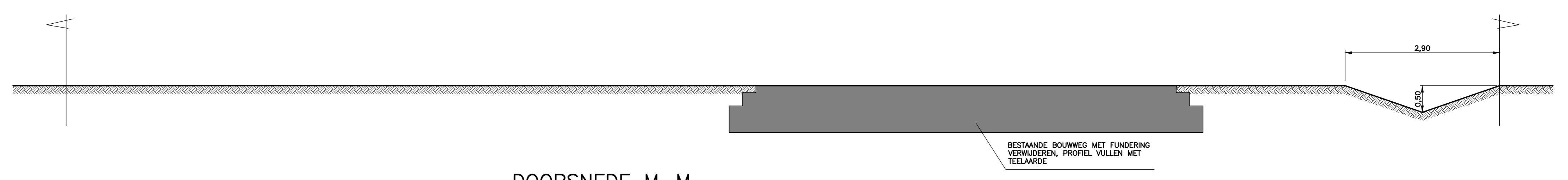
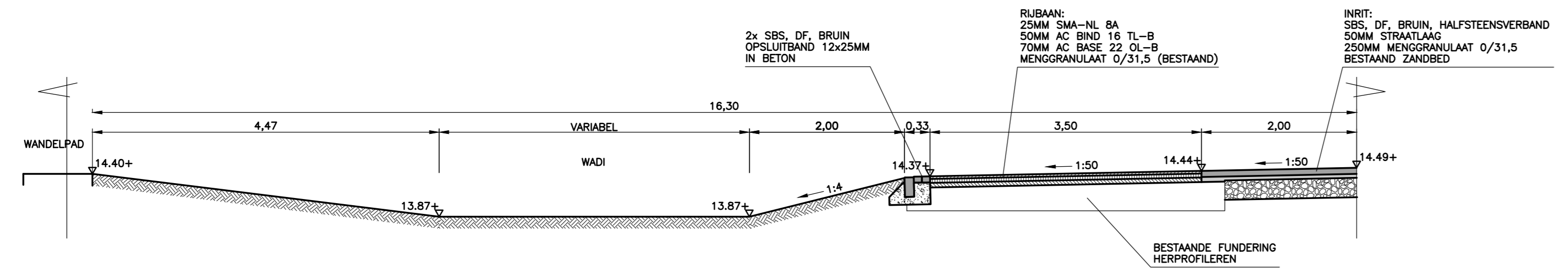
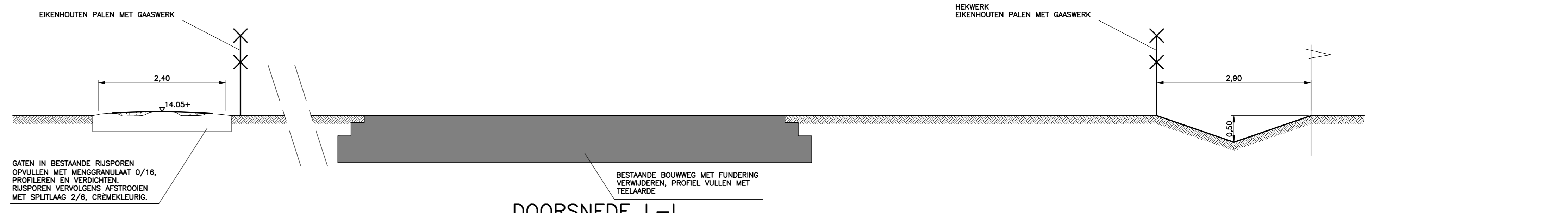
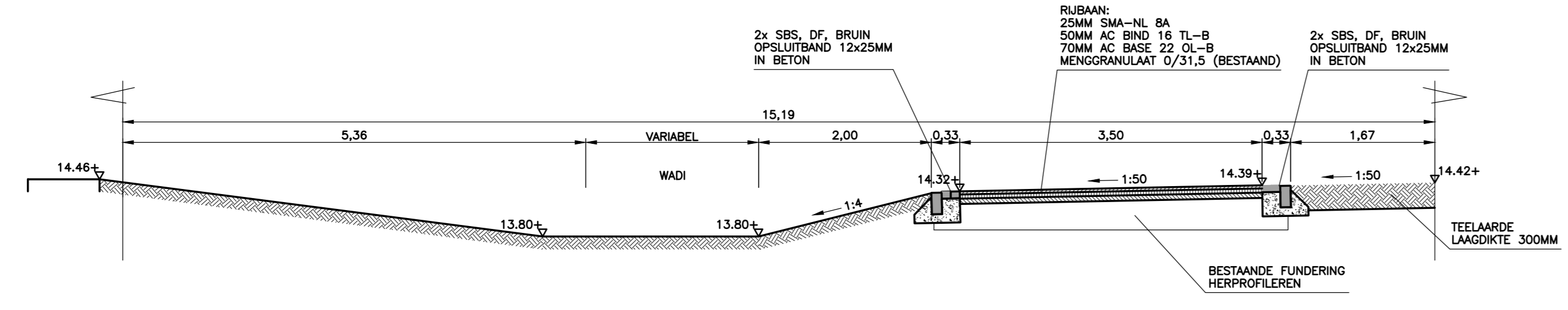
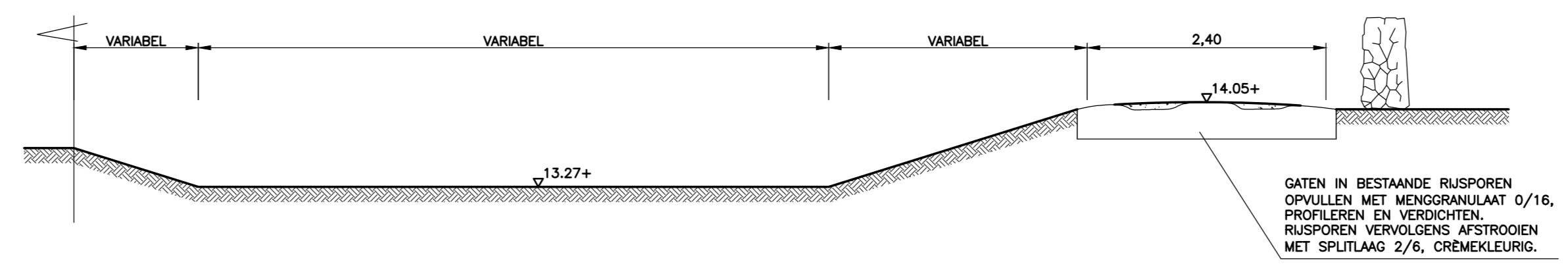
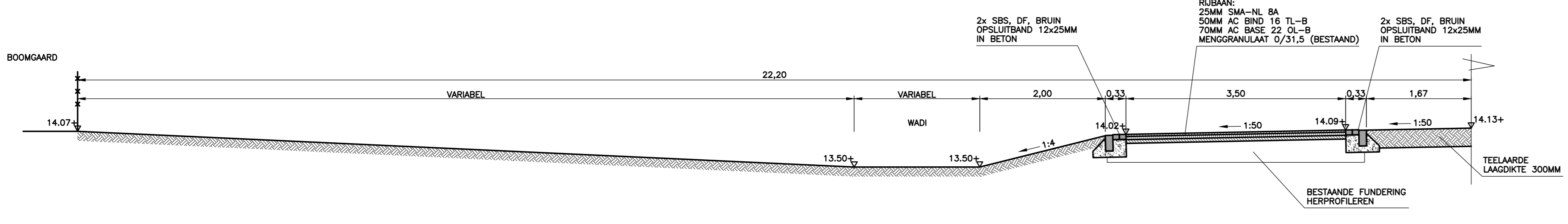
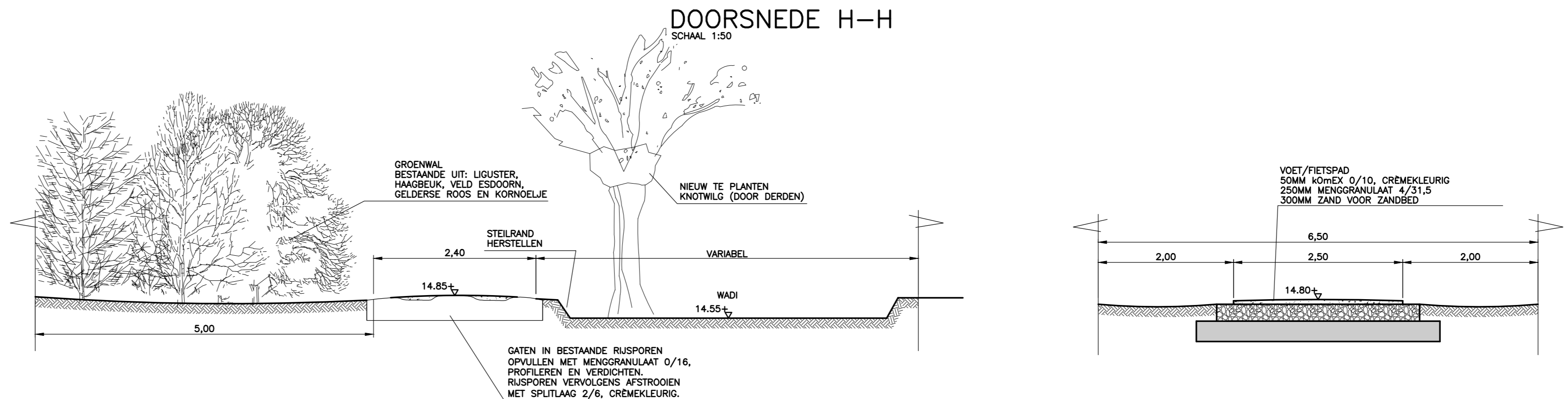
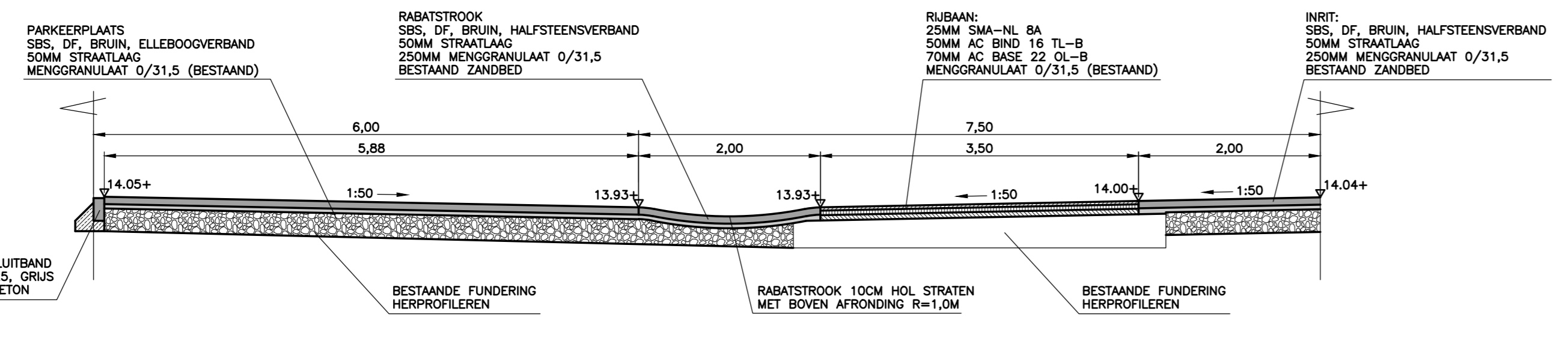
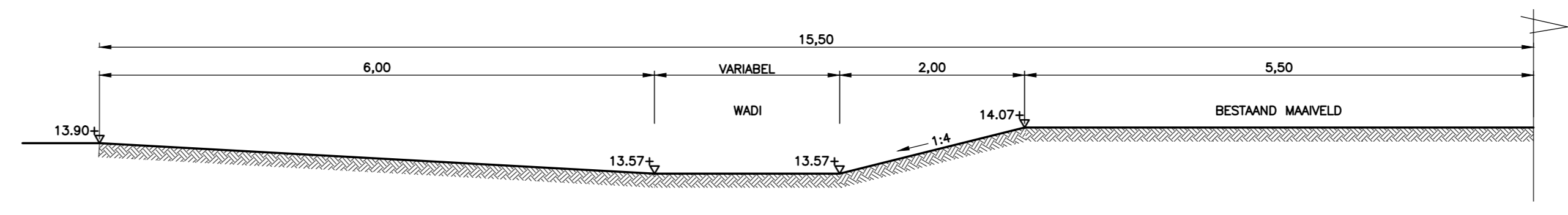
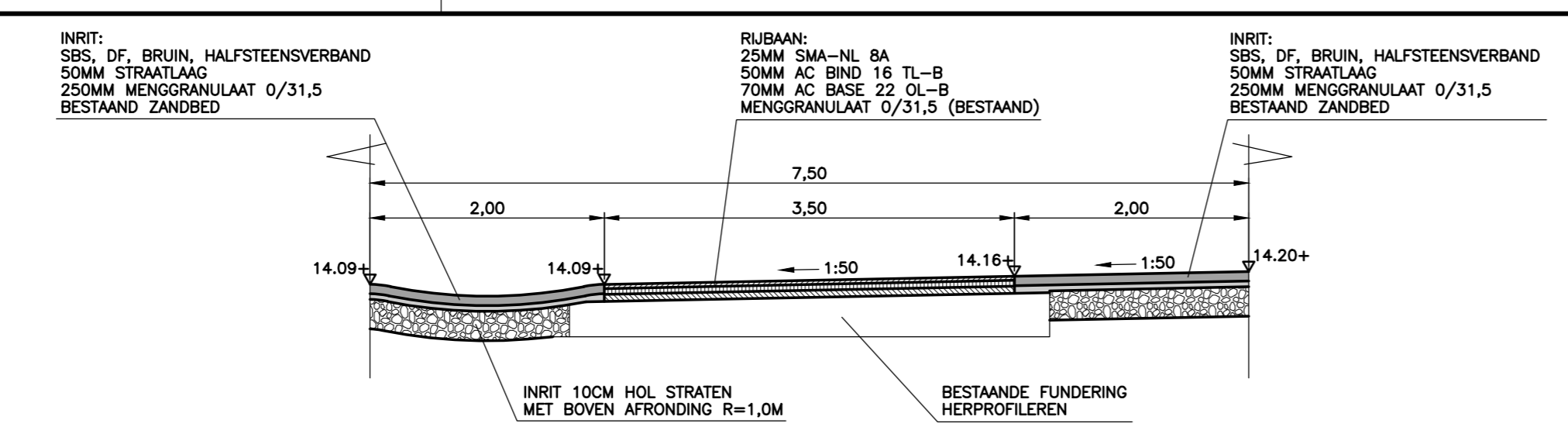

CD					
C					
B					
A					
Wp	Get.	Ass.	Daken	Onderslag	
Opdrachtgever					
gemeente Doetinchem			afdeling Fysieke Ontwikkeling Ingenieursbureau		
Project					
Woonrijp maken Heideslag Koksgeod Fase I					
Status					
DEFINITIEF					
Bouwnummer		970-4	Schaal		1:501:20
Bouwjaar		S/S	Formaat		A0
Onderwerp					
Dwarsprofielen en details					
Gedraagd					
Uitvoerder	H.V.	06-09-13	Projectnummer	9870	
Geautoriseerd	M.D.	06-09-13	Tekeningnummer	1B3103-016	
Bevestigd	M.D.	06-09-13	Aanpak		